

## Dimensions

### ■ LNTA1111

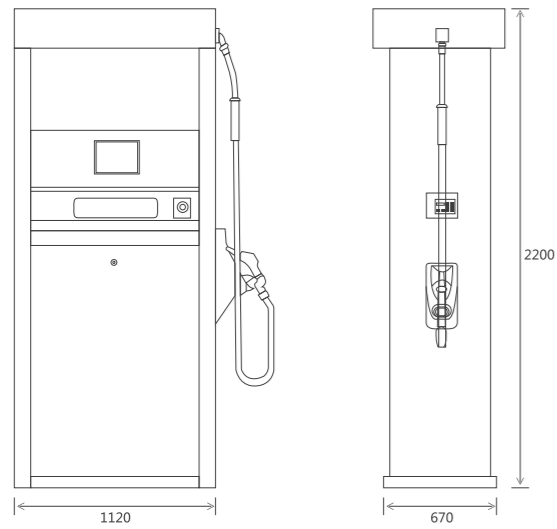

### ■ LNTA2121/LNTA2221

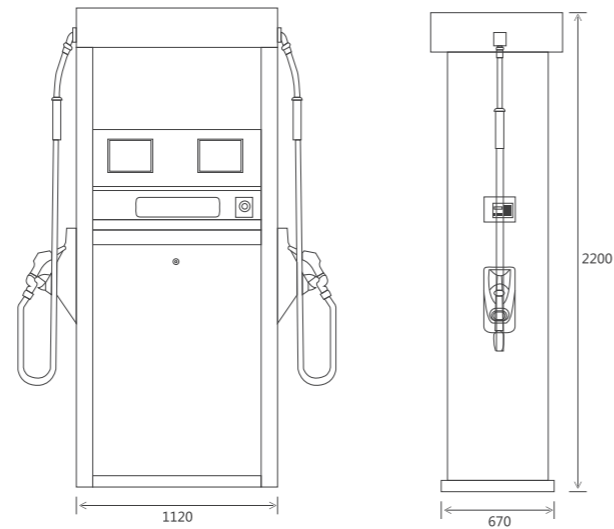

### ■ LNTA4241

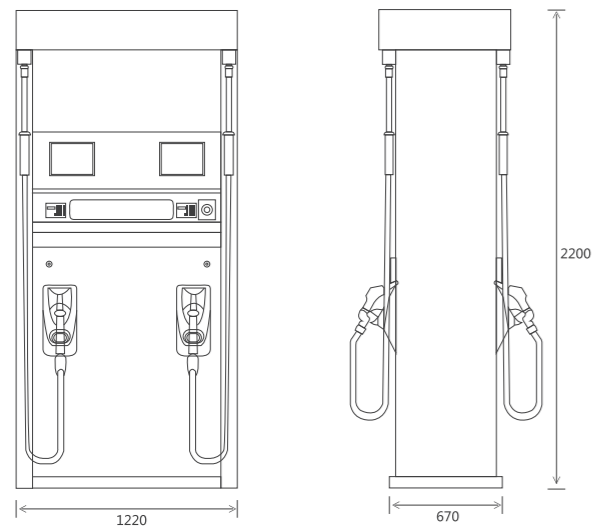

### ■ LNTA6361

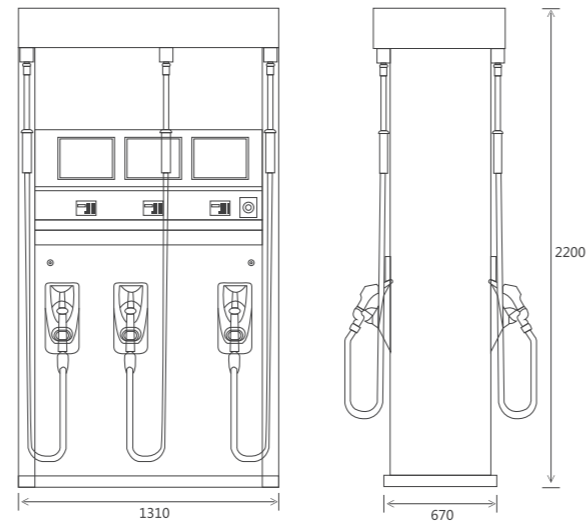

 We reserve the right to change the specifications and designs for improvement without prior notice.

### JAPAN ENERJUMP Co., Ltd.

2-4-12 KW build.4F, Nihonbashi-kakigaracho, Chuo-ku, Tokyo 103-0014 JAPAN

TEL: 03-6661-1807 FAX: 03-5651-3213

<http://www.enerjump.co.jp/> E-mail: [info@enerjump.co.jp](mailto:info@enerjump.co.jp)



MODEL   
• LANDMAN SERIES

# LANDMAN SERIES

(ランドマン シリーズ)



## Main Specifications

	Suction Pump Type	Submersible Turbine Pump (STP)Type
Flow Rate	Normal:50L/min High:70L/min Ultra-high:90L/min	Depends on the on-site STP capacity
Pump	Internal silent gear pump with air separator Suction strainer, Flexible pipe By-pass valve and Suction check valve	
Flexible Pipe	Flange type, 1-1/2" threaded	
Maunal Drive Handle	Provided for maunal operation during power failure	
Motor	Three-phase 380V 750W (Optional) Single-phase 220-240V 750W	
Meter	4-piston positive displacement flowmeter with electronic adjuster	
Accuracy	±0.3%	
Counter	Type	LCD
	Character Color	Black characters on a blue field with bright LED back light (Optional) White/Yellow/Orange back light
	Display	Sale: 8 digits[0.01~999,999.99] Liter: 8 digits[0.01~999,999.99] Unit Price: 5 digits[0.01~999.99]
	Machinery Totalizer	8 digits
	Electronic Totalizer	(Optional) 8 digits
Other Funtions	Battery back-up	
	(Optional) Self-diagnosis	
	(Optional) Over voltage protector	
Reset Device	Automatic reset	
Nozzle	Automatic nozzle, Spout outside diameter 21mm, 25mm	
Hose	Black color hose, Oil resistance type, Inside diameter 16mm (Optional) Red/Yellow/Green color hose	
Safty Breakaway Couping	Provided	
Wiring	(Optional) Cabtyre cable	
Emergency Stop Switch	Provided	
POS Interface	(Optional)	
Line Fuel Filter	(Optional)	
Anti Static Touch Pad	(Optional)	
Sight Glass	(Optional)	
Receipt Printer	(Optional)	
AD Display	(Optional)	
LED Message Board	(Optional)	
Ambient Temperature	-40 to + 60°C	
Noise	≤ 80dB (A)	
Inlet Vacuum	≥ 0.06MPa	

Wiring	LNTA1111	LNTA2121	LNTA2221	LNTA4241	LNTA6361
Apperance					
System diagram					
Dimensions	1120W*2200H*670D	1120W*2200H*670D	1120W*2200H*670D	1220W*2200H*670D	1310W*2200H*670D
weight	200kg	235kg	275kg	305kg	480kg